

# GME®

## Steel Products Catalog



*Go with the Rugged Ones!*





# Steel Shields from GME... the Trench Protection Specialists!

For over 30 years, GME® has served contractors with tough, hard-working steel trench shields designed and engineered for production and safety. We continue that tradition today with the introduction of our "Standard" and "Job-Matched" line of steel shields.

Our "Standard" line is anything *but* standard in quality and performance. It contains features that are common to all of our steel trench shields; and it is the starting point for you to **"build your own shield"** with GME®.

You can order the Standard Shield in 4", 6" and 8" wall thicknesses to match your depth requirements. Then, if necessary, you can select for your standard unit, any of the optional choices on the facing page that will make your GME® trench shield more adaptable to specific job conditions or contractor needs.

## Standard Features

Standard features are *ONLY* on 4, 6, 8-inch wall shields.



All shields are certified by a professional engineer to meet OSHA standards. To assist in OSHA compliance, a printed and laminated document with your trench shield model number and tabulated data is provided with every GME shield.

© 2006 Griswold Machine & Engineering, Inc. All specifications throughout this catalog are subject to change without notice. Products in this catalog must be used in conformity with safe practices and applicable federal, state and local codes and regulations.

# "Job-Matched" Available Options



- Foam filler
- NO knife edge (flat bottom)
- Adjustable collars (only on 3M, 4M & 4L shields)
- Bottom stacking tubes
- Pulling eyes
- Pushing pads
- Front lowered collars
- Pit kit (4-sided)
- Floating collar set (Boring application)
- Tied spreaders (connected by vertical pieces)  
Recommended for spreader widths over 60'.
- Height adapter
- End panels
- Stacking tubes
- Heavy-duty collars (7" O.D., 1" thick)
- Top angle cap

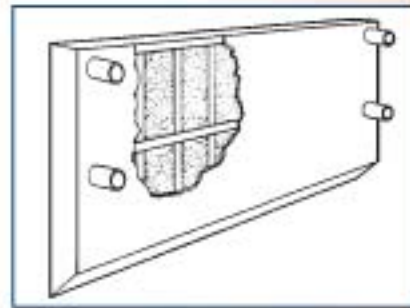

**Foam Filler** - Prevents water and mud build-up inside and adds durability.

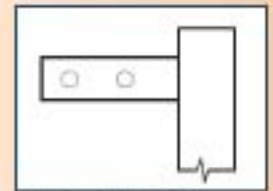

**Adjustable Collar** - Extends collar length for 12' of adjustment in 6" increments, on models 3M, 4M, or 4L ONLY.

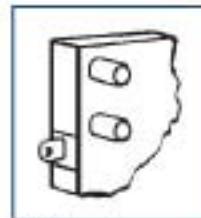

**Pulling Eyes** - Welded on face of vertical tubes for pulling the shield.



**Pushing Pads** - Welded to top horizontal at end corners.

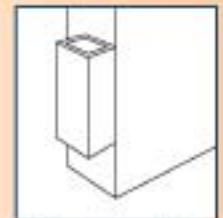

**Bottom Stacking Tubes** - 4" x 4" tubes, placed on the inside of the front vertical of the sidewall, flush to the inside.

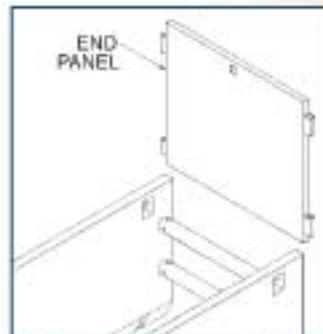
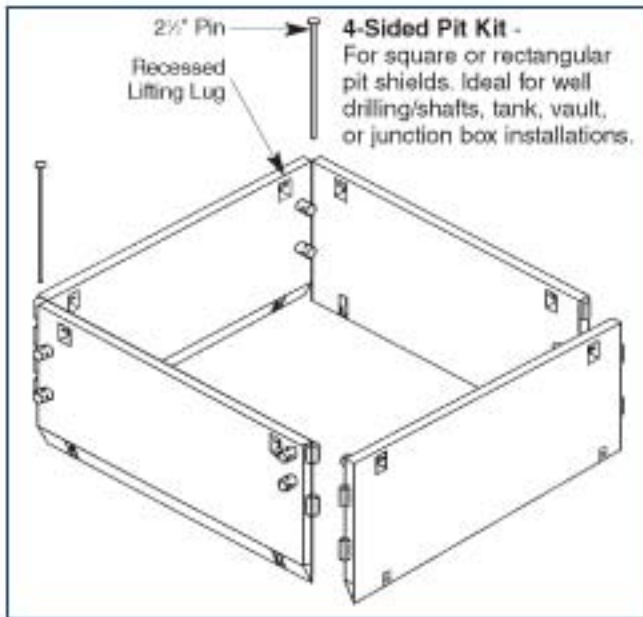

**End Panel** - Helps maintain the non-rigid movement of the shield, while providing extra protection from mud, soil, etc.

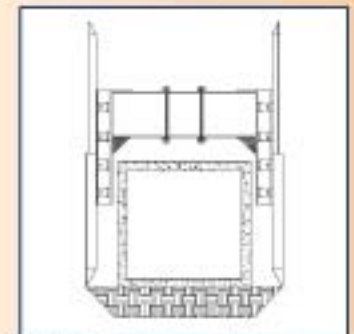

**Height Adapters** - For extra large structures or pipes, these can be used to replace the spreader pipes for extra rear clearance. It features a collar arrangement to fit the sidewalls, and is easily assembled.



# 8" WALL



**8M SERIES TRENCH SHIELD SIDEWALLS: sets of two**

MODEL	SIZE		PIPE CLEARANCE	WEIGHT (LBS)	SHIELD CAP. (PSF) (LBS)	MAXIMUM DEPTH PER SOIL TYPE (FT.) <sup>1</sup>			
	H	L				A	B	C-60	C-80
<b>DOUBLEWALL</b>									
8M416	4'	16'	16"	5538	2729	89	63	47	36
8M420	4'	20'	16"	8578	1884	89	39	30	23
8M424	4'	24'	16"	7595	1142	48	27	21	16
8M428	4'	28'	16"	8608	825	35	20	16	12
8M430	4'	30'	16"	9114	714	31	18	14	11
8M616	6'	16'	40"	7310	2031	99	68	52	40
8M620	6'	20'	40"	8774	1809	75	43	33	26
8M624	6'	24'	40"	10199	1227	52	30	23	18
8M628	6'	28'	40"	11614	887	38	23	18	14
8M630	6'	30'	40"	12322	767	34	20	16	13
8M816	8'	16'	64"	9135	2387	99	57	44	34
8M820	8'	20'	64"	11022	1873	79	46	35	27
8M824	8'	24'	64"	12854	1270	55	32	25	20
8M828	8'	28'	64"	14673	918	41	24	19	15
8M830	8'	30'	64"	15582	794	36	22	17	14
8M1016	10'	16'	76"	10059	2109	89	52	40	31
8M1020	10'	20'	76"	13271	1687	72	42	33	26
8M1024	10'	24'	76"	15510	1296	57	34	27	21
8M1028	10'	28'	76"	17731	997	42	26	21	17
8M1030	10'	30'	76"	18842	810	37	23	19	15

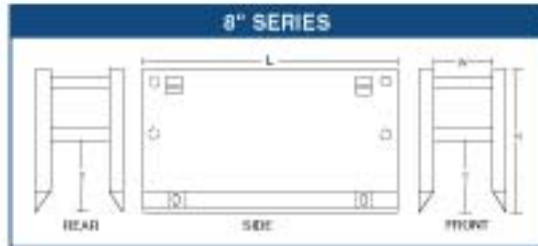

**8H SERIES TRENCH SHIELD SIDEWALLS: sets of two**

MODEL	SIZE		PIPE CLEARANCE	WEIGHT (LBS)	SHIELD CAP. (PSF) (LBS)	MAXIMUM DEPTH PER SOIL TYPE (FT.) <sup>1</sup>			
	H	L				A	B	C-60	C-80
<b>DOUBLEWALL</b>									
8H416	4'	16'	16"	8161	3426	99	78	59	45
8H420	4'	20'	16"	7359	2310	94	53	41	31
8H424	4'	24'	16"	8535	1567	65	37	28	22
8H428	4'	28'	16"	9706	1132	47	27	21	16
8H430	4'	30'	16"	10291	980	41	24	18	14
8H616	6'	16'	40"	8255	3731	99	86	65	50
8H620	6'	20'	40"	9999	2496	99	58	45	34
8H624	6'	24'	40"	11623	1893	71	41	31	24
8H628	6'	28'	40"	13279	1223	52	30	23	18
8H630	6'	30'	40"	14105	1058	45	27	21	16
8H816	8'	16'	64"	10401	2387	99	57	44	34
8H820	8'	20'	64"	12610	1910	80	46	36	28
8H824	8'	24'	64"	14764	1591	68	39	31	24
8H828	8'	28'	64"	16904	1269	55	32	25	20
8H830	8'	30'	64"	17974	1098	48	29	22	18
8H1016	10'	16'	76"	12547	2971	99	58	45	35
8H1020	10'	20'	76"	15282	1897	81	47	37	29
8H1024	10'	24'	76"	17904	1581	68	40	31	25
8H1028	10'	28'	76"	20528	1297	57	34	27	21
8H1030	10'	30'	76"	21841	1122	50	30	24	19

**BDS Spreader Sets: For use on 4L, 4M, 6M, 6H, 8M & 8H Shields; 8" Schedule 80 Pipe**

	Model	80524	80533	80538	80542	80548	80560	80572	80584	80596	80618	806126	806132	806144
	Inside Width	24'	30'	36'	42'	48'	60'	72'	84'	96'	108'	120'	132'	144'
For 6' & 8' HIGH	Wt. lbs.	387	474	561	647	734	908	1081	1255	1428	1602	1776	1949	2123

BDS Spreaders include 2" diameter pin

<sup>1</sup>Depths are based on A,B,C-60 and C-80 soil types as described in OSHA's 29 CFR Part 1926 Subpart P, October 31, 1989, and publications of the Trench Shoring & Shielding Association (TSSA), with Type A not exceeding 25 PSF per foot of depth, Type B not exceeding 45 PSF per foot of depth, Type C-60 not exceeding 60 PSF per foot of depth, Type C-80 not exceeding 80 PSF per foot of depth. Determine actual soil pressures and consult Manufacturer's Tabulated Data prior to each use.

# 6" WALL



## 6M SERIES SHIELD SIDEWALLS: sets of two

MODEL	SIZE		PIPE CLEARANCE	WEIGHT (LBS)	SHIELD CAP. (PSF) (LBS)	MAXIMUM DEPTH PER SOIL TYPE (FT.) <sup>1</sup>			
	H	L				A	B	C-60	C-80
<b>DOUBLEWALL</b>									
6M416	4'	16'	16"	4975	2073	85	48	37	28
6M420	4'	20'	16"	5936	1280	53	30	23	18
6M424	4'	24'	16"	6873	868	37	21	16	13
6M428	4'	28'	16"	7804	627	27	16	12	10
6M616	6'	16'	40"	8612	2195	91	52	40	30
6M620	6'	20'	40"	7976	1355	57	33	26	20
6M624	6'	24'	40"	9300	919	40	23	18	14
6M626	6'	26'	40"	9957	776	34	20	16	13
6M628	6'	28'	40"	10613	664	30	18	14	11
6M816	8'	16'	64"	8300	2168	91	52	40	31
6M820	8'	20'	64"	10068	1393	60	35	27	21
6M824	8'	24'	64"	11778	945	42	25	20	16
6M826	8'	26'	64"	12626	798	36	22	17	14
6M828	8'	28'	64"	13474	683	31	19	15	13
6M1016	10'	16'	76"	9989	1537	66	39	31	24
6M1020	10'	20'	76"	12160	1230	54	32	25	20
6M1024	10'	24'	76"	14257	960	43	28	21	17
6M1026	10'	26'	76"	15296	811	37	23	19	15
6M1028	10'	28'	76"	16335	694	33	20	17	14



## 6H SERIES SHIELD SIDEWALLS: sets of two

MODEL	SIZE		PIPE CLEARANCE	WEIGHT (LBS)	SHIELD CAP. (PSF) (LBS)	MAXIMUM DEPTH PER SOIL TYPE (FT.) <sup>1</sup>			
	H	L				A	B	C-60	C-80
<b>DOUBLEWALL</b>									
6H416	4'	16'	16"	5588	2627	99	60	46	35
6H420	4'	20'	16"	6717	1774	73	41	32	24
6H424	4'	24'	16"	7812	1209	50	29	22	17
6H428	4'	28'	16"	8902	868	37	21	16	13
6H516	6'	16'	40"	7556	2824	99	66	50	38
6H520	6'	20'	40"	9161	1885	78	45	34	27
6H524	6'	24'	40"	10724	1278	54	31	24	19
6H526	6'	26'	40"	11501	1080	46	27	21	16
6H528	6'	28'	40"	12277	924	40	24	18	15
6H816	8'	16'	64"	9566	2387	99	57	44	34
6H820	8'	20'	64"	11656	1910	80	46	36	28
6H824	8'	24'	64"	13687	1317	57	33	26	20
6H826	8'	26'	64"	14696	1112	48	29	23	18
6H828	8'	28'	64"	15705	952	42	25	20	16
6H1016	10'	16'	76"	11576	2129	90	52	40	32
6H1020	10'	20'	76"	14151	1704	73	43	33	26
6H1024	10'	24'	76"	16651	1340	59	35	27	22
6H1026	10'	26'	76"	17691	1132	50	30	24	19
6H1028	10'	28'	76"	19132	958	44	27	21	17

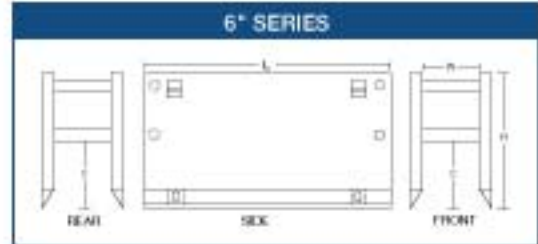

## 8DS Spreader Sets: For use on 4L, 4M, 6M, 6H, 8M & 8H Shields; 8" Schedule 80 Pipe

	Model	8D624	8D630	8D636	8DS42	8DS48	8DS60	8DS72	8DS84	8DS96	8DS108	8DS120	8DS132	8DS144
	Inside Width	24"	30"	36"	42"	48"	60"	72"	84"	96"	108"	120"	132"	144"
For 6" & 8" 6M Series	Wt. lbs.	387	474	561	647	734	908	1091	1255	1428	1602	1776	1949	2123

8DS Spreaders include 2" diameter pin



<sup>1</sup>Depths are based on A,B,C-60 and C-80 soil types as described in OSHA's 29 CFR Part 1926 Subpart P, October 31, 1989, and publications of the Trench Shoring & Shielding Association (TSSA), with Type A not exceeding 25 PSF per foot of depth, Type B not exceeding 45 PSF per foot of depth, Type C-60 not exceeding 60 PSF per foot of depth, Type C-80 not exceeding 80 PSF per foot of depth. Determine actual soil pressures and consult Manufacturer's Tabulated Data prior to each use.



# 4" WALL



## 4L SERIES SHIELD SIDEWALLS: sets of two

MODEL	SIZE		PIPE CLEARANCE	WEIGHT (LBS)	SHIELD CAP. (PSF) (LBS)	MAXIMUM DEPTH PER SOIL TYPE (FT.)*			
	H	L				A	B	C-60	C-80
<b>SINGLEWALL</b>									
4L46SW	4'	6'	16"	1776	3319	99	76	57	43
4L48SW	4'	8'	16"	2044	1517	63	98	27	21
4L410SW	4'	10'	16"	2312	908	38	22	17	13
4L412SW	4'	12'	16"	2566	604	26	15	12	10
4L66SW	6'	6'	40"	2135	1627	68	39	30	23
4L68SW	6'	8'	40"	2505	1250	53	31	24	19
4L610SW	6'	10'	40"	2881	870	38	22	17	14
4L612SW	6'	12'	40"	3218	578	26	16	13	10
4L86SW	8'	6'	48"	2525	1165	51	30	23	19
4L88SW	8'	8'	48"	3004	919	41	24	19	15
4L810SW	8'	10'	48"	3487	735	33	20	16	13
4L812SW	8'	12'	48"	3917	565	27	17	13	11
<b>DOUBLEWALL</b>									
4L410	4'	10'	16"	2576	1662	68	39	30	23
4L412	4'	12'	16"	2874	1385	57	33	25	19
4L414	4'	14'	16"	3172	1187	49	28	22	17
4L416	4'	16'	16"	3470	906	38	22	17	13
4L610	6'	10'	40"	3343	1733	72	42	32	25
4L612	6'	12'	40"	3775	1444	61	35	27	21
4L614	6'	14'	40"	4206	1238	53	31	24	18
4L616	6'	16'	40"	4638	938	41	24	19	15
4L810	8'	10'	48"	4149	1770	75	43	33	26
4L812	8'	12'	48"	4714	1475	63	37	29	22
4L814	8'	14'	48"	5280	1264	55	32	25	20
4L816	8'	16'	48"	5845	954	42	25	20	16
4L820	8'	20'	48"	6976	592	28	17	14	11

## 4" SERIES



## 4M SERIES SHIELD SIDEWALLS: sets of two

MODEL	SIZE		PIPE CLEARANCE	WEIGHT (LBS)	SHIELD CAP. (PSF) (LBS)	MAXIMUM DEPTH PER SOIL TYPE (FT.)*			
	H	L				A	B	C-60	C-80
<b>DOUBLEWALL</b>									
4M412	4'	12'	16"	3501	2575	99	59	45	34
4M416	4'	16'	16"	4318	1418	59	34	26	20
4M420	4'	20'	16"	5180	876	37	21	17	13
4M424	4'	24'	16"	5984	569	25	15	11	9
4M612	6'	12'	40"	4622	2696	99	63	48	37
4M616	6'	16'	40"	5708	1473	62	36	29	21
4M620	6'	20'	40"	6903	909	39	23	18	14
4M624	6'	24'	40"	8170	579	26	16	13	10
4M812	8'	12'	64"	5787	1868	79	46	35	27
4M816	8'	16'	64"	7302	1401	60	35	27	22
4M820	8'	20'	64"	8871	926	41	25	19	16
4M824	8'	24'	64"	10401	583	27	17	14	11
4M1016	10'	16'	76"	8817	694	45	27	22	17
4M1020	10'	20'	76"	10749	795	37	23	18	15
4M1024	10'	24'	76"	12633	586	28	18	15	12



## 8DS Spreader Sets: For use on 4L, 4M, 6M, 6H, 8M & 8H Shields; 8" Schedule 80 Pipe

	Model	8DS24	8DS36	8DS48	8DS60	8DS72	8DS84	8DS96	8DS108	8DS120	8DS132	8DS144		
	inside Width	24'	30'	36'	42'	48'	60'	72'	84'	96'	108'	120'	132'	144'
For 6' & 8' HIGH	Wt. lbs.	387	474	561	647	734	908	1081	1255	1428	1602	1776	1949	2123

8DS Spreaders include 2" diameter pin

\*Depths are based on A.B.C-60 and C-80 soil types as described in OSHA's 29 CFR Part 1926 Subpart P, October 31, 1989, and publications of the Trench Shoring & Shielding Association (TSSA), with Type A not exceeding 25 PSF per foot of depth, Type B not exceeding 45 PSF per foot of depth, Type C-60 not exceeding 60 PSF per foot of depth, Type C-80 not exceeding 80 PSF per foot of depth. Determine actual soil pressures and consult Manufacturer's Tabulated Data prior to each use.

# 3" WALL



## 3L SERIES TRENCH SHIELD SIDEWALLS: sets of two

MODEL	SIZE		PIPE CLEARANCE	WEIGHT (LBS)	SHIELD CAP. (PSF) (LBS)	MAXIMUM DEPTH PER SOIL TYPE (FT.) <sup>a</sup>			
	H	L				A	B	C-60	C-80
3L46	4'	6'	24"	673	1142	48	27	21	16
3L48	4'	8'	24"	835	827	35	20	16	12
3L410	4'	10'	24"	995	523	23	14	11	9
3L412	4'	12'	24"	1158	350	16	10	8	8
3L66	6'	6'	24"	921	1244	53	31	24	19
3L68	6'	8'	24"	1151	742	33	19	15	12
3L610	6'	10'	24"	1381	460	22	13	11	9
3L612	6'	12'	24"	1611	329	16	10	8	7
3L86	8'	6'	24"	1189	1125	49	29	23	18
3L88	8'	8'	24"	1467	699	32	20	16	13
3L810	8'	10'	24"	1765	442	22	14	11	10
3L812	8'	12'	24"	2064	304	16	11	9	8

## 3SQ Spreader Sets: for 3L Series Shields; 3" x 3" x 3/16" tube (includes all attaching hardware)

Model	3SQ24	3SQ30	3SQ36	3SQ42	3SQ48	3SQ60	3SQ72	3SQ84	3SQ96
Inside Width	24"	30"	36"	42"	48"	60"	72"	84"	96"
Wt. lbs.	77	88	100	111	123	146	169	192	216



3L SERIES

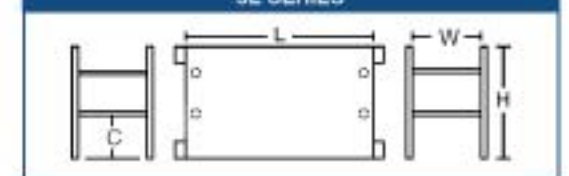

## 3M SERIES TRENCH SHIELD SIDEWALLS: sets of two

MODEL	SIZE		PIPE CLEARANCE	WEIGHT (LBS)	SHIELD CAP. (PSF) (LBS)	MAXIMUM DEPTH PER SOIL TYPE (FT.) <sup>a</sup>				
	H	L				A	B	C-60	C-80	
<b>3M SINGLEWALL</b>										
3M46SW	4'	6'	24"	831	1958	80	46	35	26	
3M48SW	4'	8'	24"	1090	1118	47	27	21	16	
3M410SW	4'	10'	24"	1228	678	29	17	13	10	
3M412SW	4'	12'	24"	1427	453	20	12	10	8	
3M66SW	6'	6'	36"	1113	1766	74	42	32	25	
3M68SW	6'	8'	36"	1380	981	42	25	19	15	
3M610SW	6'	10'	36"	1647	594	27	16	13	10	
3M612SW	6'	12'	36"	1914	397	19	12	10	8	
3M86SW	8'	6'	51"	1409	1033	45	27	21	17	
3M88SW	8'	8'	51"	1745	775	35	21	17	14	
3M810SW	8'	10'	51"	2080	551	26	16	13	11	
3M812SW	8'	12'	51"	2415	359	19	12	10	9	
<b>3M DOUBLEWALL</b>										
3M6DCW	6'	8'	36"	1772	1643	69	40	30	24	
3M610CW	6'	10'	36"	2140	1314	56	32	25	19	
3M612CW	6'	12'	36"	2508	1015	44	26	20	16	
3M8DCW	8'	8'	51"	2295	1226	53	31	24	19	
3M810CW	8'	10'	51"	2772	981	43	26	20	16	
3M812CW	8'	12'	51"	3240	817	37	22	18	14	



3M SERIES



## 5DS Spreader Sets: For use on Shields; 5" Schedule 80 Pipe

Model	5DS24	5DS30	5DS36	5DS42	5DS48	5DS60	5DS72	5DS84	5DS96	5DS108	5DS120
Inside Width	24"	30"	36"	42"	48"	60"	72"	84"	96"	108"	120"
Wt. lbs.	186	228	269	311	352	436	519	602	685	768	851

<sup>a</sup>Depths are based on A,B,C-60 and C-80 soil types as described in OSHA's 29 CFR Part 1926 Subpart P, October 31, 1989, and publications of the Trench Shoring & Shielding Association (TSSA), with Type A not exceeding 25 PSF per foot of depth, Type B not exceeding 45 PSF per foot of depth, Type C-60 not exceeding 60 PSF per foot of depth, Type C-80 not exceeding 80 PSF per foot of depth. Determine actual soil pressures and consult Manufacturer's Tabulated Data prior to each use.



# Manhole Shields



**\*OPTIONAL CUT-OUTS AVAILABLE**

24' x 24'  
36' x 36'

## MH SERIES MANHOLE SHIELDS: with spreaders and attaching hardware

MODEL	SIZE			PIPE CLEARANCE	WEIGHT (LBS)	SHIELD CAP. (PSF) (LBS)	MAXIMUM DEPTH PER SOIL TYPE (FT.) <sup>1</sup>			
	H	W	L				A	B	C-60	C-80
<b>MH SERIES SINGLEWALL (STEEL)</b>										
MH8SW	8'	8'	8'	45"	3717	655	30	19	15	12
MH10SW	8'	10'	10'	45"	4270	426	21	13	11	9
MH48SW	4'	8'	8'	N/A	2533	884	37	22	17	13
MH410SW	4'	10'	10'	N/A	2920	575	25	15	12	9
<b>MH SERIES DOUBLEWALL (STEEL)</b>										
MH8DW	8'	8'	8'	45"	4387	2160	90	52	40	31
MH10DW	8'	10'	10'	45"	5084	1641	70	40	31	25
MH12DW	8'	12'	12'	45"	5781	1297	56	33	26	20
MH48DW	4'	8'	8'	N/A	2868	2180	88	50	38	29
MH410DW	4'	10'	10'	N/A	3332	1813	75	42	32	25
MH412DW	4'	12'	12'	N/A	3999	1347	56	32	24	19
<b>MH SERIES DOUBLEWALL (STEEL) WITH CUT-OUTS</b>										
MH8DW w/CO	8'	8'	8'	45"	4387	1924	81	47	36	28
MH10DW w/CO	8'	10'	10'	45"	5084	1262	54	32	25	20
MH12DW w/CO	8'	12'	12'	45"	5781	879	39	24	19	15

Our MH Series made of high tensile steel, are heavier and are rated for deeper jobs. The square manhole configuration surrounds the pit and provides the needed inside clearspan while reducing the amount of excavation and restoration required. They assemble in minutes at the jobsite. Standard models include two walls, two spreader assemblies, eight holding pins and keepers. All are certified by a professional engineer to meet OSHA standards.



**OPTIONAL LEGS AVAILABLE**

**OPTIONAL Cut-out Sizes:**  
8.5' x 8' shield:  
Two: 55" w x 40" h  
One: 29" w x 24" h  
10' x 8' shield:  
Two: 72" w x 48" h  
One: 41" w x 30" h

# Round Manhole Shields

## RMH SERIES ROUND MANHOLE SHIELDS

MODEL	SIZE		WEIGHT (LBS)	SHIELD CAP. (PSF) (LBS)	MAXIMUM DEPTH PER SOIL TYPE (FT.) <sup>1</sup>			
	Diameter	Height			A	B	C-60	C-80
RMH 8.5 x 4	8.5'	4'	920	1920	32	32	32	21
RMH 8.5 x 8	8.5'	8'	1609	1920	32	32	32	21
RMH 10 x 4	10'	4'	1100	1882	32	32	32	21
RMH 10 x 8	10'	8'	1959	1882	32	32	32	21
RMH 8.5 x 8 w/RC	8.5'	8'	2319	1649	25	25	25	17
RMH 10 x 8 w/RC	10'	8'	2675	1649	25	25	25	17

Specially designed for personal protection during manhole installations and repair work. High strength steel walls, welded securely to rigid steel top and bottom framing. Optional replaceable cut-outs allow for clearance of utility lines. RMH Shields are light enough for handling with rubber-tired backhoes, yet provide maximum protection for workers in the hole.



# Bedding Boxes



All Boxes below include Apparatus A

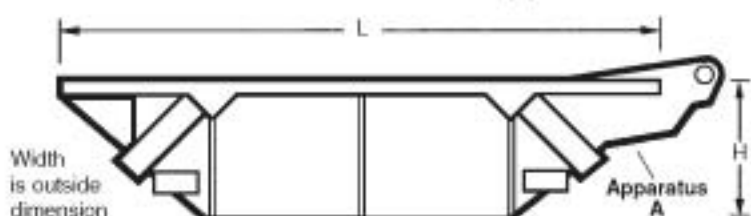

## LIGHT DUTY BEDDING BOXES includes Apparatus "A"

Model No.	Capacity	Wt. Lbs. (empty)	Outside Width	Outside Length	Height
BL-4	4 CYDS	3,228	54"	13'	44"
BL-7	7 CYDS	4,480	60"	16'	44"
BL-9	9 CYDS	5,061	72"	16'	44"

## STANDARD DUTY BEDDING BOXES - Includes Apparatus "A"

BS-5	5 CYDS	4,423	60"	13'	44"
BS-7	7 CYDS	5,078	60"	16'	44"
BS-8	8 CYDS	5,133	66"	16'	44"
BS-9	9 CYDS	5,608	72"	16'	44"

## HEAVY DUTY BEDDING BOXES - Includes Apparatus "A"

BH-9	9 CYDS	6,310	72"	16'	44"
BH-12	12 CYDS	7,438	96"	16'	44"
BH-15	15 CYDS	8,766	96"	20'	44"

## LIGHT DUTY BEDDING BOXES

The BL4, BL7, and BL9 Light Duty are designed for use with lighter machinery. The top frame is further strengthened by an inner core of hardwood. It is constructed of 3/16" plate at the ends and sides, and 3/8" plate on the bottom. Wear strip on bottom and a 44" profile is standard on these boxes.

## STANDARD DUTY BEDDING BOXES

BS5, BS7, BS8 and BS9. The Standard unit features rugged steel welded construction, fully reinforced at all points of stress. The top frame is further strengthened by an inner core of hardwood. This unit is constructed of 1/4" sides and ends, and the bottom surface is smooth; fabricated of 1/2" steel plate, with wear strips on the inside to guard against damage by bucket teeth. Low 44" profile allows dump truck to fill the box from either end or side.

## HEAVY DUTY BEDDING BOXES

BH9, BH12, and BH15. The BH Heavy Duty box is just right for use with heavy machinery. The top frame is further strengthened by an inner core of hardwood. It is constructed of 3/8" plate at sides and ends and 1/2" plate on the bottom. Wear strips are on the inside bottom and a 44" profile are standard on the heavy duty box. The clean sweep end and corners are reinforced for that extra toughness often required for many construction needs.



## Apparatus "B" Option

The Apparatus "B" option, available on all models of the GME bedding box, makes repositioning the box easy and quick. It is reinforced and fully welded at all stress points and gussets have been added for extra strength.





# Slide Rail System



GME/E+S Modular Slide Rail System in a linear application.



GME/E+S Modular Slide Rail System used for a pit application.

- Fast, easy assembly
- Great performance at all depths
- For pits, tank installations, pipeline jobs, and more
- Exact alignment in the trench
- Minimal site restoration required
- Patented open track system lets you swing panels into place for safer, easier assembly
- Certified to meet OSHA Requirements

Do you have a congested work site? Are the compaction specifications difficult to achieve? It is exactly these types of tough job-site conditions for which the GME/E+S slide rail system was designed. Over thirty years of continuous use in Europe, the Emunds & Staudinger slide rail system is now available to U.S. contractors through its partnership with GME. The GME/E+S system with its unique features is setting new performance standards for speed and safety on the jobsite in the most challenging situations. Whether it is a deep cut for larger diameter pipe, exacting compaction specifications, or a jobsite in which ground subsidence must be kept to a minimum, the GME/E+S system is the most cost effective choice available to contractors today.

This unique modular system is especially useful when the jobsite is impacted by adjacent structures such as buildings or retaining walls or when vehicle traffic is adjacent to the excavation. As the system is installed, the machine operator is able to dig deep while keeping soil tight to the modular panels and rails. This method effectively reduces soil subsidence typical to excavations employing other shoring systems such as trench shields. Similarly, a contractor can frequently do his work safely and efficiently while allowing vehicle traffic to continue adjacent to the work site itself. Is this possible with other systems? Only at much greater costs in time and materials. The GME/E+S system is your choice for a cost effective job.

User friendly and low in maintenance, this modular slide rail system will provide the cost conscious contractor with the competitive edge for years to come. These advantages are achieved through a patented open track system. The only one of its kind on the North American continent.

Contact GME for full details, including animated video and job stories, and see how the GME/E+S system can work on your project.

# Custom Products



GME® pioneered the trench shield industry, entering it in 1967, and quickly taking a leadership position in product engineering, design and marketing. We currently have two plants in Union City, Michigan, devoted exclusively to trench shield and shoring production, and have also opened a plant in Nevada.

Skilled labor, unique production methods, and high quality materials assure you of getting uniform quality components in every trench shield you buy.

Shown here are some examples of GME's custom design capabilities. Boring shields, extra-long shields, custom height adapters... if you need it, **we can do it.**



Custom shield with height adapter.



Custom shield with height adapter.

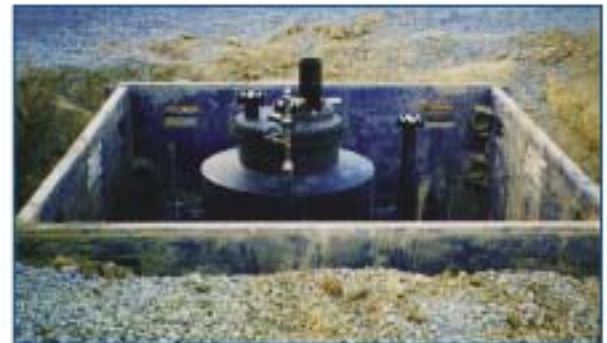

GME shields in a pit application.



Special shield using a custom bedding slide.



Pit application with stacked shields.



**GRISWOLD MACHINE & ENGINEERING, INC.**

594 Mendon Road • Union City, MI 49094  
1-800-248-2054 • 517-741-4300 • Fax: 517-741-7483  
[www.gme-shields.com](http://www.gme-shields.com)



4AEX Aluminum Shield



Lite-Shield™ Modular Shoring



Hydraulic Vertical Shoring



Heavy Duty Water Systems

GME® is the leader in lightweight shields and shoring for municipalities and contractors. Contact GME® or your dealer for information on hydraulic products, Lite-Shield™ systems, Slide Rail systems and other trench protection products.

MEMBER:



Slide Rail Systems

Your GME® Dealer: